



# INSTALLATION AND START UP USER'S MANUAL

## CMU-324HE For Europe

This document was formulated in Japan. Comply with the regulations and standards of the country of use regarding installation and usage.

The specifications of products and components may vary with country of use and the site situation.

INFORMATION IN THIS MANUAL MAY BE CHANGED  
WITHOUT NOTICE.

MIURA CO., LTD.

Manual Code No.

S855-080-6013

**<Precautions for installation and use> — Safety information**

When installing and using a piece of water treatment equipment, you are obligated as an operator to submit official notification, and to install, construct and utilize your equipment strictly in compliance with applicable laws and regulations. In order that your MIURA water treatment equipment can be put to safe and reliable use, it is crucial that in addition to fulfilling these legal obligations, you also establish and implement a safety management system.



**This section highlights situations where failure to follow MIURA guidelines could lead to serious injury or death.**

**(1) Relocation & Resale**

If you intend to relocate or sell your MIURA water treatment equipment, contact your dealer or MIURA sales office in order that installation work can be carried out correctly and that the peripheral equipment may be set up. In addition, ensure that Operation Manual and the like are kept in order that they may also be provided to the new owner in the event of resale.

**(2) Prohibition of Modification without Permission**

Customization or modification not recommended by MIURA may present safety problems and is therefore prohibited. If you wish to modify your water treatment equipment, contact your dealer or MIURA sales office in advance. It should be noted that MIURA will accept no responsibility for the outcome of unapproved customization.

**(3) Drain Piping**

Ensure that drain piping is fixed securely in place to prevent it from moving in reaction to drain discharge and that the end of the piping opens in a safe location such as a pit. Failure to observe this precaution may lead to electric shock or other problems due to splashing of water. Do not touch the drain piping as the discharged water may be high temperature in some cases depending on the product used. Touching the drain pipe may result in burns or other injury.

High concentration water may be discharged from the water treatment equipment temporarily in some cases. Additional water treatment may be necessary to prevent lakes and other bodies of water from being adversely affected depending on the volume of drain and the water quality.

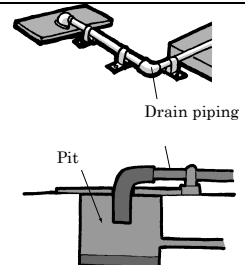
**(4) Electrical Work**

When connecting a power supply to the water treatment equipment, use wire of the specified rating and ensure that the equipment are correctly grounded (Japanese D-type grounding work or better). Furthermore, a dedicated power supply should be used, and an earth leakage circuit breaker (with overcurrent protection) should be installed. If this precaution is not observed, serious accidents such as electric shock and the outbreak of fire may result.

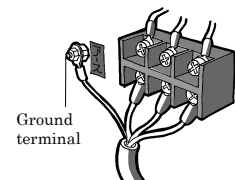
**NOTE****(1) Exporting from Japan**

Under the Foreign Exchange and Foreign Trade Act, permission must be granted in advance by the Government of Japan for products under export control to be shipped overseas. In addition, many countries have enacted regulations and the like covering the import and usage of products from Japan—in certain cases, import and use of these products is prohibited. Therefore, if you wish to export your water treatment equipment from Japan, contact your dealer or MIURA sales office in advance.

**(2) Water Treatment Equipment Installation**

Ensure that the installation work for the water treatment equipment is carried out correctly as set forth in the applicable MIURA Installation Manual. Furthermore, anybody who will work with the water treatment equipment should carefully study the content of the Operation Manual in advance and ensure that it is fully understood.

**(3) Water Leakage Countermeasures**

Factors such as loose connectors and aging of pipe materials can lead to water leakage. It is important that drain ditches be setup for the water treatment equipment and all peripheral equipment. (In order to prevent water from leaking outside the room or downstairs, set up a drain ditch that completely encloses the whole equipment, ensure that the floor itself is waterproof, make the floor slope downward to the drain port, and take any other necessary steps.)

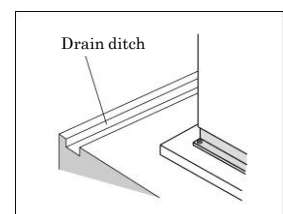

**<Precautions for installation and use> — Related laws and regulations**

- 1) The table below shows part of the laws and regulations on equipment installation and use. Refer to the separate document for more information on other relevant laws and regulations.  
(There are also prefectural and municipal ordinances; therefore, contact the supervisory authority or competent authority for more information.)
- 2) The information listed in the table was created based on the laws and regulations in effect when the information was published.
- 3) The documents to be submitted and their destination vary depending on your equipment and facilities.  
If you have any questions, contact your nearest dealer, MIURA sales office, or the competent supervisory authority.
- 4) The laws and regulations listed below may not apply to all water treatment equipment. Refer only to those laws and regulations that apply to your equipment and facilities.

Related laws and regulations	Form(s) to be submitted	Destination	Submission timing	Remarks
Water Quality Pollution Control Act, River Act, Sewerage Service Act, etc.	Verification required from local towns and cities in which the water treatment equipment or other equipment is installed. (The laws and regulations in some areas may be defined even more specifically in accordance with regional regulations.)			Drain water may be produced depending on the type of water treatment equipment and equipment operation. Drain water must be treated in other ways to prevent it from damaging waterways and the like. In cases where the total amount of drain water exceeds the legal amount on a per-plant basis or where the equipment is used at specified facilities, an application is necessary. However, the conditions may vary from region to region. Accordingly, you should contact your local authorities for more information.
Regional Pollution Prevention Ordinance	Notification as required by the applicable ordinance	As set forth by the relevant regional authorities	As set forth by the relevant regional authorities	Applicability is defined independently by regional pollution prevention ordinances based; accordingly, you should contact your local authorities for more information. (Certain regional ordinances concerning air pollution, noise, vibration, drain water, and the like may supersede the corresponding national regulations.)
Water Supply Act	None	—	—	(Prohibition of direct waterworks contact) Water treatment equipment (excluding certified equipment) cannot be connected directly to waterworks. Instead, it is necessary to either set up a feed water tank or to isolate the systems using, for example, a float valve. Details may vary from region to region; accordingly, you should contact your local authorities for more information.
	Design specifications for dedicated waterworks, Notification of the start of feeding water	As set forth by the relevant regional authorities	—	Business operators are to submit notification to local governments for drinking water wells for industrial use in facilities where the volume of water intake exceeds the allowed quantity as prescribed by law which require the use of dedicated waterworks systems regardless of the form of usage. Contact your local authorities for details.
Act on Maintenance of Sanitation in Buildings	None	—	—	Buildings are to be preserved and maintained (through cleaning, water quality analysis, and other activities) in accordance with Hygiene Control Standards.
Food Sanitation Act	No notification made for equipment and related matters	—	—	Measures are to be implemented to maintain hygiene and safety and prevent sanitation hazards in accordance with applicable laws.
Industrial Safety and Health Act	None	—	—	When using substances specified in applicable laws (such as specified chemical substances), a qualified operator must be selected, all such substances are to be handled and managed in accordance with applicable laws, and the operator's healthcare is necessary.
Poisonous and Deleterious Substances Control Act	None	—	—	All such substances are to be stored and managed in accordance with applicable laws. Chemical substances are to be handled properly in accordance with the guidance and information listed on the SDS for the relevant material.
Fire Service Act	Notification as set forth by local fire departments	The nearest fire department	Prior to the start of work	Local fire chiefs or fire department chiefs must be notified in advance of any plans for any party to use or store certain substances (chemical substances and other materials) of a designated quantity as specified by applicable laws and regulations.

## Introduction

This document describes the methods of installing the Colormetry CMU-324HE (for hardness) (hereinafter called “the equipment”) to ensure its proper use.

Before installing the equipment, ensure that this document is read and fully understood; furthermore, the instructions given herein should be strictly observed during installation and test operation.

Safety-related warnings are classified according to the following three levels, and notification of these warnings is provided within this manual.



Indicates an imminently dangerous situation which leads to serious injury or death to the user, if the product is mishandled.









Indicates a situation which might cause serious injury or death to the user, if the product is mishandled.



Indicates a situation which might cause minor injury to the user or the occurrence of physical damage only, if the product is mishandled.

[Explanation of Notation]

The meanings of the symbols used in this manual are as shown below.

	Indicates a prohibited action (what you must not do).
	Indicates a possibility of injury when a specific location of the product is touched.
	Indicates a possibility of electric shock when the product is handled with wet hands.
	Indicates an action to be taken according to an instruction (what to be executed).
	Indicates an action connecting a grounding wire.
	Indicates a warning or caution
	Indicates a possibility of injury due to high temperatures under specific conditions.
<b>NOTE</b>	Used to highlight important information to prevent equipment malfunction as well as tips for efficient work and other useful information.

## Table of contents

<b>1</b>	<b>PREPARATION FOR INSTALLATION</b> .....	<b>1</b>
1.1	Installation Location.....	1
1.2	Protective Equipment .....	1
<b>2</b>	<b>INSTALLATION</b> .....	<b>2</b>
<b>3</b>	<b>PIPING</b> .....	<b>4</b>
3.1	Drain System (see Fig.2-3).....	4
3.2	Feed-Water System (see Fig.3-1) .....	5
<b>4</b>	<b>Electrical wiring</b> .....	<b>8</b>
4.1	Routing the wires (see Fig.4-1) .....	8
4.2	Remote Alarm Output .....	11
4.3	Remote Signal Input.....	12
4.4	Water Passing Output.....	13
<b>5</b>	<b>INSTALLING THE REAGENT CARTRIDGE</b> .....	<b>14</b>
<b>6</b>	<b>START UP</b> .....	<b>16</b>
6.1	Checking the Installation .....	16
6.2	Checking the Wiring .....	16
6.3	Checking the Piping.....	16
6.4	Setting Before Supplying the Power .....	18
6.5	Power Supply .....	20
6.6	Setting Mode .....	23
6.7	Monitor Operation.....	27
6.8	Alarm Setting.....	28

# 1 PREPARATION FOR INSTALLATION

## 1.1 Installation Location

Check the following items before installing the equipment.

### NOTE

(Installation location)

- The equipment is designed to hang on a wall. Install it indoors, away from rain.
- Provide sufficient work space around the equipment for maintenance and operation.
- Avoid a location subject to direct sunlight.
- Install the equipment in such a way that the length of feed-water tube between the main piping and the equipment is within 16.4 ft (5 m).

(Electrical wiring)

- The power supply is specified at DC24V. A source is required near the equipment.
- The DC24V input should be supplied by a power supply (AC adaptor) as a LPS (Limited Power Source) under the EN60950-1.

(Piping)

- The raw water pressure range (both static and dynamic) must always be 7.2 to 71 psi (0.05 to 0.5 MPa). If the pressure is outside that range, a pressurizing unit or pressure-reducing valve will be required.

(Raw water and installation environment)

- Use the equipment with raw water in the 41 to 104°F (5 to 40°C) range. Using water outside that range may damage the internal components.
- Use the equipment in an ambient temperature range of 41 to 122°F (5 to 50°C). Temperatures outside this range may cause deterioration of the reagent.
- The drain-water tube included in the equipment is 9.8 ft (3 m) long, requiring a nearby drain ditch.

### **Water Leakage Countermeasures**

Factors such as loose connectors and aging of pipe materials can lead to water leakage. It is important that drain ditches be setup for the water treatment equipment and all peripheral equipment. (In order to prevent water from leaking outside the room or downstairs, set up a drain ditch that completely encloses the whole equipment, ensure that the floor itself is waterproof, make the floor slope downward to the drain port, and take any other necessary steps.)

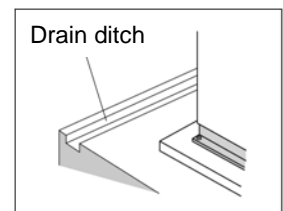

## 1.2 Protective Equipment

Wear protective items such as a helmet, safety glasses, a safety mask, safety footwear, and leather gloves as necessary for the task in hand.

## 2 INSTALLATION

### **WARNING**



Do not insert fingers into the reagent cartridge receptacle. There is possibility of injury by chemical injection roller inside the equipment.

### **CAUTION**



Do not insert any objects into the reagent cartridge receptacle other items. It will cause an evaluation and system errors. Even if the equipment is not to use for a while and disconnect from the power supply, do not remove the reagent cartridge to prevent a contamination.

#### **NOTE**

The reagent cartridge's receptacle is plugged when the equipment is delivered. Do not remove it until installation is completed. (see Fig.2-1)

\* If the plug is removed, the stirrer inside may roll out and get lost. An extra stirrer is attached to the back of the front cover in case one is lost.

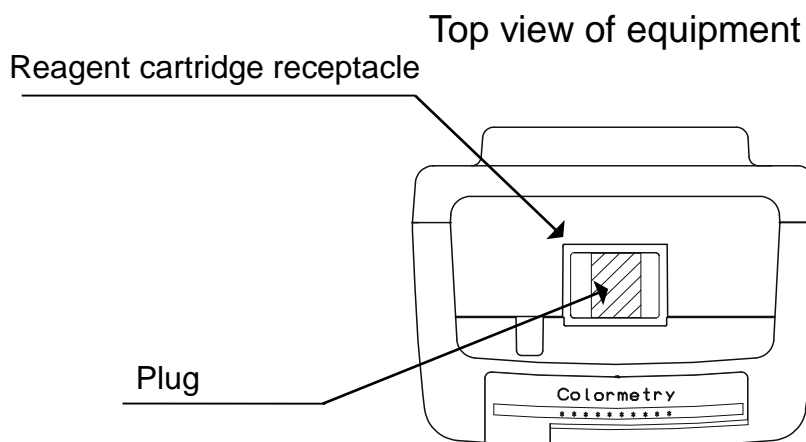

Fig.2-1 Reagent cartridge's receptacle

How to install the equipment on the wall (see Fig.2-2)

[1] Screw the mounting bracket, supplied with the equipment, where the equipment is to be installed.

The equipment should be installed at a height to allow easy reading of the LCD.

\*Install the mounting bracket with its rounded side up.

\*The sample water collecting point (branching from main piping) to the filter casing assembly should be within 1m.

\*If the Colormetry is installed much higher place, it might cause an evaluation error because of the lack of sample water.

[2] Hook the equipment on the mounting bracket on the wall and screw down the bottom plate of the equipment.

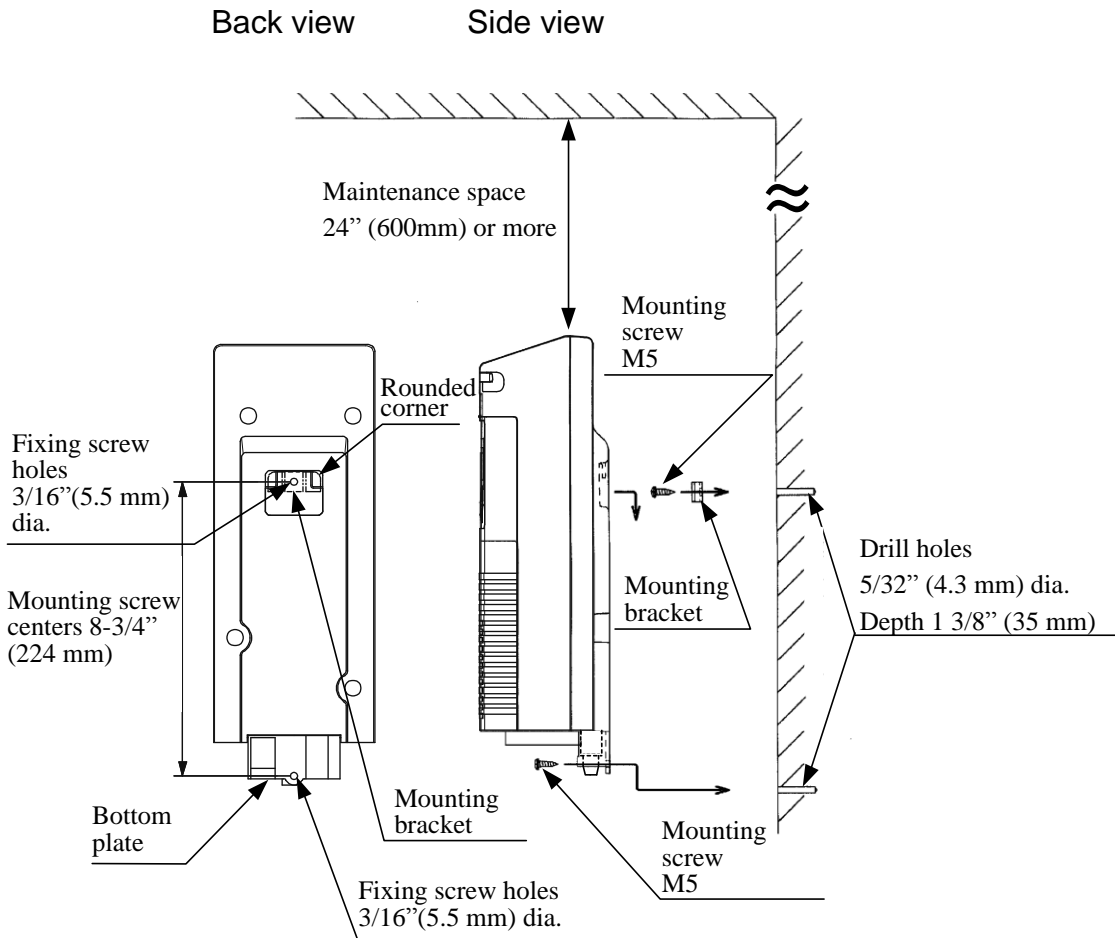

Fig.2-2 Installation of the equipment

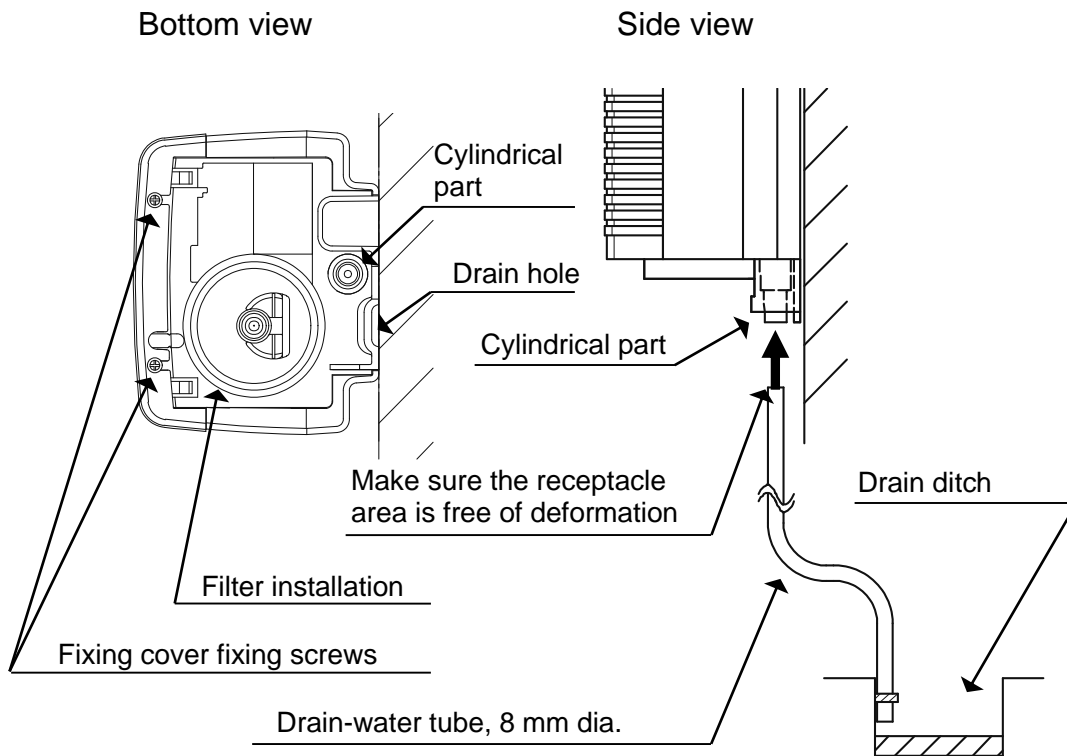

Fig.2-3 Installation of the drain-water tube



### 3 PIPING

#### 3.1 Drain System (see Fig.2-3)

[1] Cut the drain-water tube, 8 mm dia. supplied with the equipment, to the length required for drainage.

[2] Firmly insert one end of the drain-water tube into the cylindrical part at the bottom of the equipment. Run the other end into a drain ditch.

\*The insertion of the drain-water tube into the cylindrical part requires some force. Make sure the end of the tube for connection does not have excessive deformation or burrs before inserting the tube.

#### **NOTE**

Do not connect the drain-water tube to other line of pipings.

Drain-water tube end must open into the air.

Exercise care in keeping the drain-water tube free of bents or folds. An obstructed drain-water tube may cause water leakage and misevaluation.

In case the drain-water tube is clogged and the internal pressure builds up, the equipment will relieve the pressure through either of the methods (1) and (2) shown below.

(1) Water leaks out of the tube connection at the bottom.

(2) Water leaks out of the internal piping.

These methods cause drain water to leak down through the drain hole at the bottom of the equipment. Be sure not to leave anything underneath the equipment.

### 3.2 Feed-Water System (see Fig.3-1)

- [1] Attach the ball valve supplied with the equipment, to the sample water collecting point. Then, attach tube joint to the ball valve.
- [2] Cut the feed-water tube, 6 mm dia., came with the equipment, to the length required for the installation, and firmly inserts the end into the tube joint.
- [3] Assemble the filter casing assembly according to the following procedure. (see Fig.3-2)
  - (1) Take the filter casing assembly out of the bag. Fit the constant flow valve into the end of bottom tip of it.
    - \* Be careful not to lose the constant flow valve during installation.
    - Use an extra constant flow valve is attached to the box of the fiber filter in case one is lost.
  - (2) The filter casing assembly comes apart into two sections. To take them apart, rotate the top and bottom sections in a counterclockwise direction.
  - (3) Remove the fiber filter from the box (and bag). Insert the tip end of the fiber filter into the center of the filter case (top). Then firmly tighten the filter case (top) and filter case (bottom) back together.
- [4] Screw the filter casing assembly into the bottom of the equipment. There is no need for concern about tightening it hard, since the O-ring at the end of the filter casing assembly provides a sufficient seal on the lateral part.
  - \*When you install the filter casing assembly, simply screw it in by hand. Do not use any kind of fitting tool. If you use tools to screw in with excess power, the filter casing assembly and the bottom plate of the Colormetry might be broken.
- [5] Insert the feed-water tube into the tube joint on the bottom of the filter casing assembly.
- [6] Use the cable ties came with the equipment to bundle the 6 mm dia. feed-water tube and the 8 mm dia. drain-water tube.

(Doing so will prevent the 8 mm drain-water tube form dropping out of the equipment if external force is exerted upon it.)

Bundle them together about 6 to 8 inches (150 to 200 mm) away from the bottom of the filter casing assembly. If the bundle point is too close to the filter casing assembly, undue force may be exerted on the tube joint and cause water leakage.

**NOTE**

Exercise care in keeping the feed-water tube free of bents and folds.

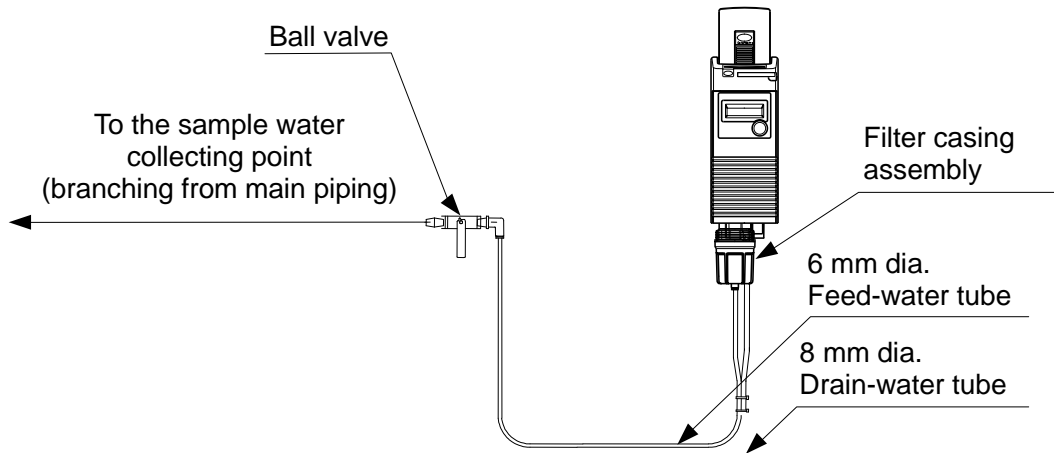

Fig3-1 Feed-water system

**NOTE**

Where zinc or copper piping is used, zinc or copper ions would dissolve and stagnate in the water. The reagent in this system reacts with zinc and copper ions. Take the sample water collecting point as close to the water softener as possible to avoid the effects of ions dissolving out of the piping.

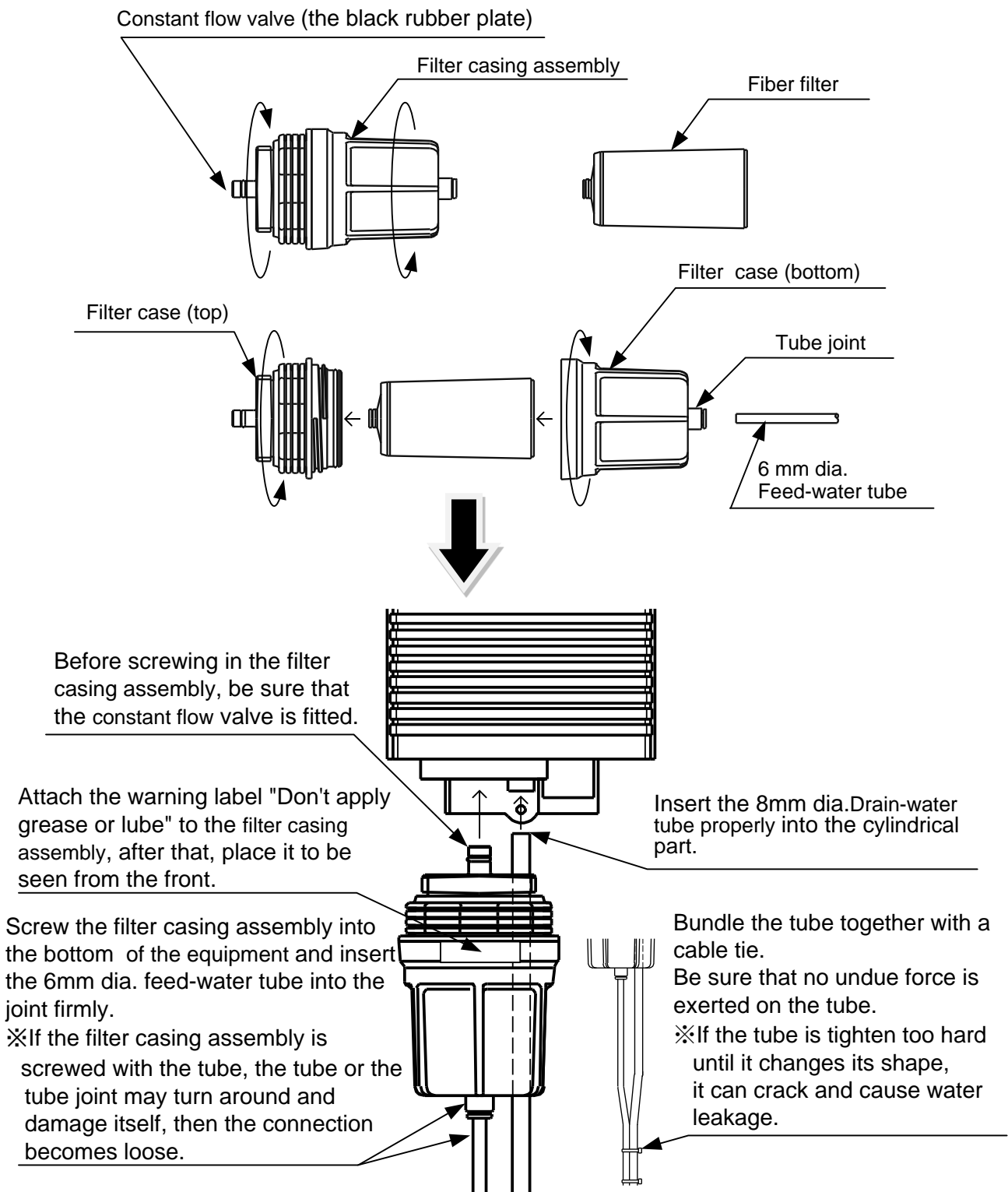

Fig. 3-2 Filter casing assembly installation

\* When you exchange the fiber filter, please loosen the filter casing assembly after closing the ball valve at the sample water collecting point.

## 4 Electrical wiring

### 4.1 Routing the wires (see Fig.4-1)

#### **WARNING**



Do not touch the power switch with wet hands.  
Failure to observe this precaution could result in an electric shock.



When connecting a power supply to the product, use wire of the specified rating and ensure that the equipment are correctly grounded (Japanese D-type grounding work or better).

Furthermore, a dedicated power supply should be used, and an earth leakage circuit breaker (with overcurrent protection) should be installed. If this precaution is not observed, serious accidents such as electric shock and the outbreak of fire may result. In case of emergency, the power supply has to cut immediately. Install an earth leakage circuit breaker at the easy accessible location.

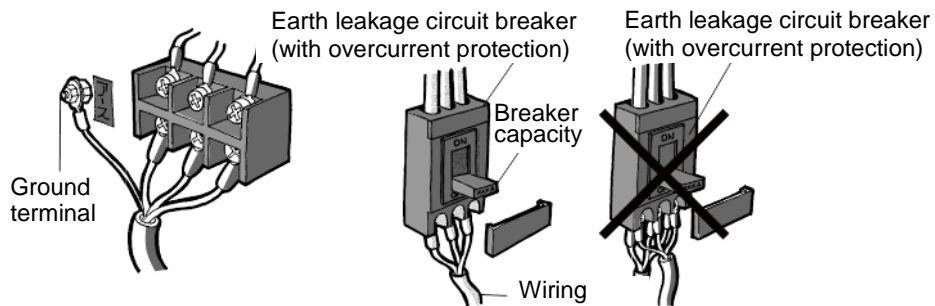

#### **WARNING**



Do not supply the power to the equipment while wiring. If wirings touch the circuit board, it may cause malfunction of the equipment or electric shock.

#### **CAUTION**



Remove static electricity from body before taking off the front cover. Failure to observe this precaution could result malfunction of the equipment.

- [1] Loosen the front cover fixing screws at the bottom of the equipment and remove the front cover.
- [2] Pass the wires through the wire holder and wiring window in the bottom plate of the equipment and connect the wires to the terminal on the circuit board.
- [3] Provide a drooping slack for the wires, and clamp them.

**NOTE**

The power supply is specified at DC24V.

Use a wire of 18-16AWG (0.75 mm<sup>2</sup>) for the power supply.

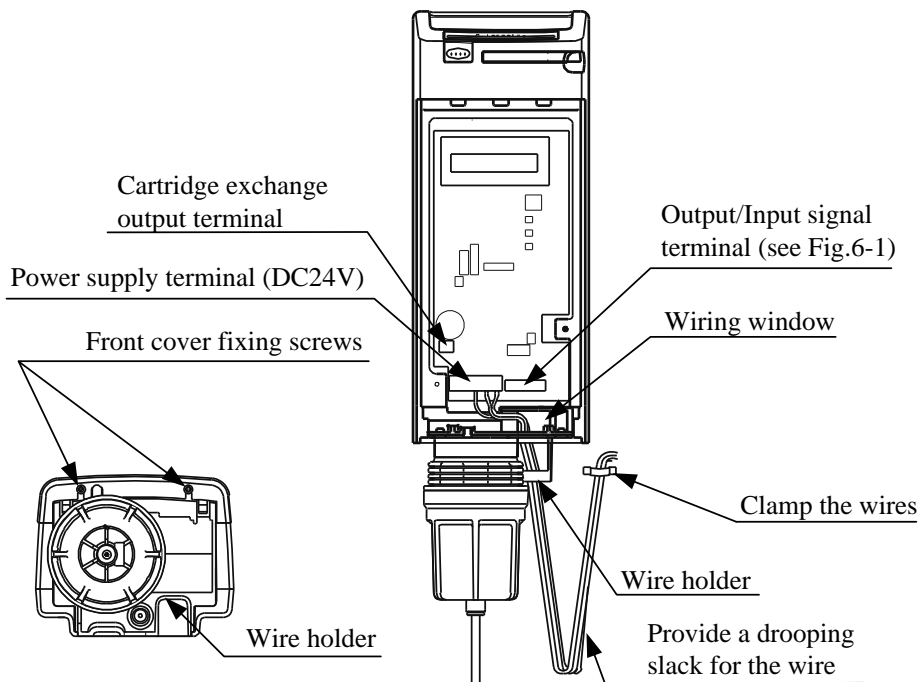
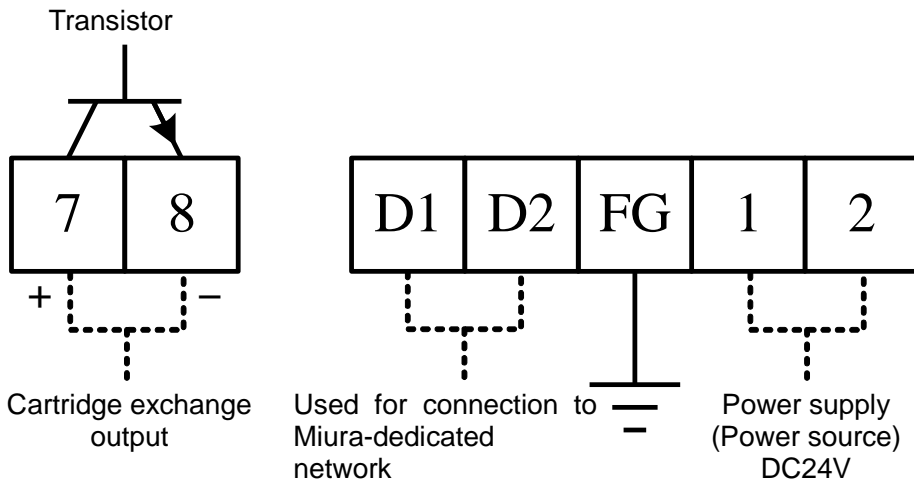

Fig.4-1

**NOTE**

The equipment starts operating as soon as the power is supplied.

Supply the power to the equipment only when it is ready for start up.



The caution symbol of the terminal TB1 indicates that the FG terminal is a functional ground terminal.

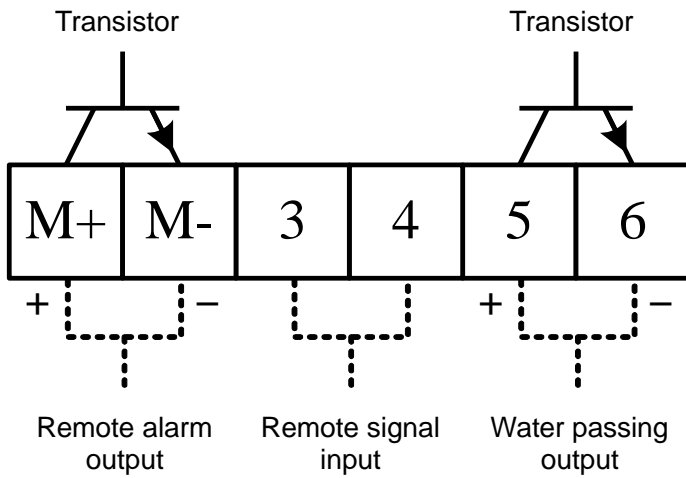

Fig.4-2 External terminal

**NOTE**

The cable length should be 30 m or less.

## 4.2 Remote Alarm Output

The remote alarm output is an open collector output. Maximum rating is DC24V 70mA. When the DC24V switching power supply and DC24V relay are connected to the remote alarm output, the signal can be transmitted as a contact output in case that concentration anomaly or system error occurs in the equipment

Note: DC relay with built-in coil-type surge-suppressing diode (24V,70mA max.)

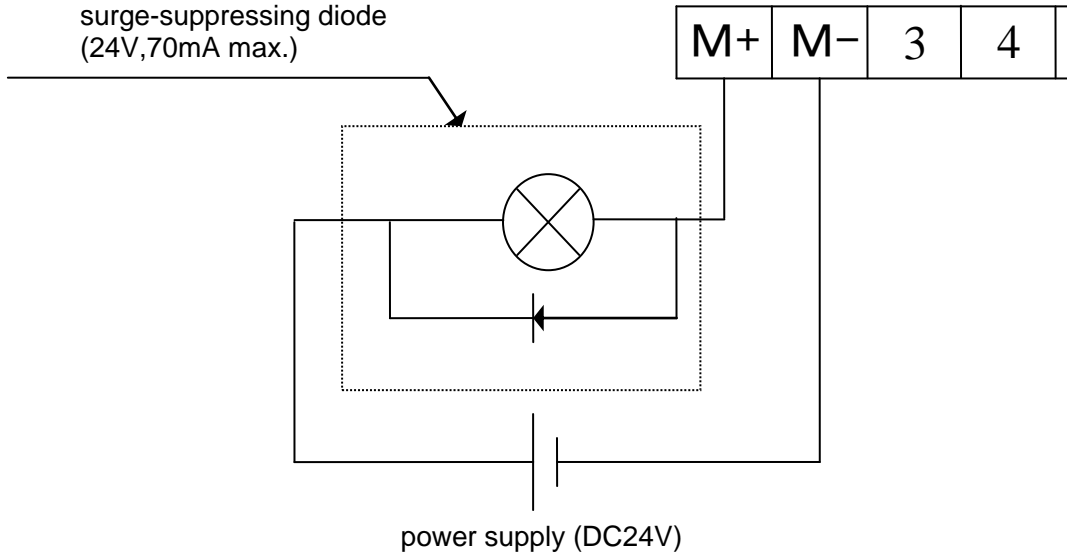

Fig.4-3

- \* A DC relay with built-in coil-type surge-suppressing diode is recommended.
- If an ordinary type DC relay is to be used, connect a diode in parallel with the relay.



### 4.3 Remote Signal Input

Connecting the external contact with no-voltage enables to remotely control the equipment whether to perform monitoring or not.

At setting mode on LCD, a remote signal may be utilized in either two methods as below.

the ON state (Monitoring is enable by remote signal being turned ON and disable by turned OFF)

the OFF state (Monitoring is enable by remote signal being turned OFF and disable by turned ON)

Either the "A" or "B" contact may be used.

Connecting the external contract with no-voltage as shown in Fig.4-4

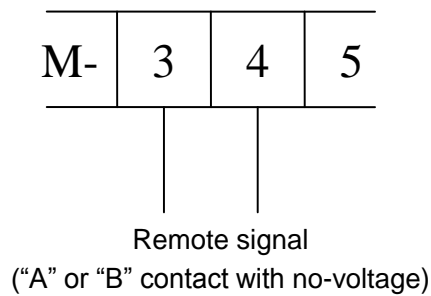

Fig.4-4

#### **NOTE**

The feeding water signal, if available, should be utilized as the first propriety.

If not, set up the monitor start and stop times at the setting mode on the LCD to avoid monitoring during water is stopped, which might cause a system error of the equipment

#### 4.4 Water Passing Output

The water passing output is an open collector output that turns on only during the washing process.

When the DC24V switching power supply and DC24V relay are connected to the water passing output, the signal can be transmitted as a contact output in case of washing process.

See Fig.4-5 to connect the output as required.

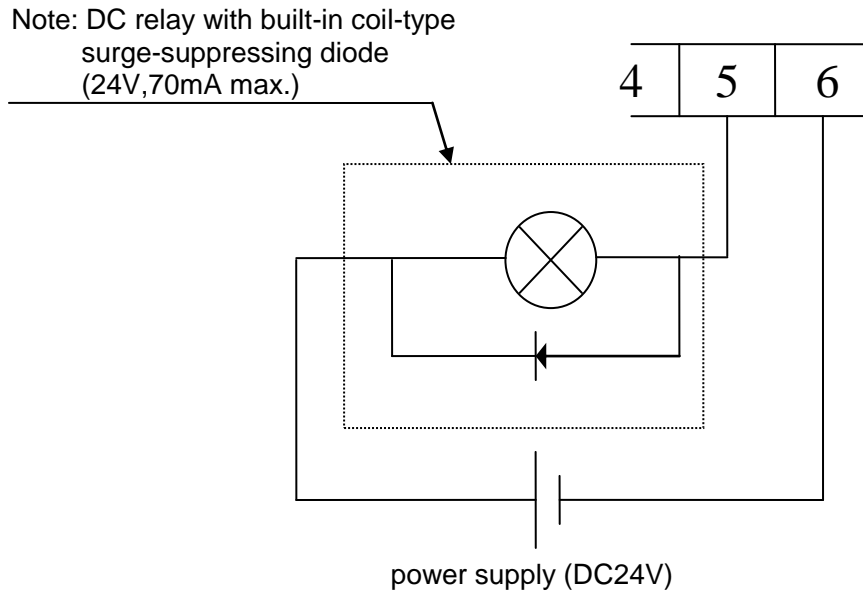

Fig.4-5

\* A DC relay with built in coil-type surge-suppressing diode is recommended.

If an ordinary type DC relay is to be used, connect a diode in parallel with the relay.

#### **NOTE**

Turning a relay on and off generates sufficient back EMF across its coil to destroy a transistor when opening of the relay. Be sure to connect a surge suppresser in order to protect the transistor.

## 5 INSTALLING THE REAGENT CARTRIDGE



Never disassemble the reagent cartridge.  
Reagent may splatter onto the skin or the eyes.  
If the reagent gets on the skin or in the eyes, rinse immediately with water.

- [1] Remove the plug from the reagent cartridge receptacle in the equipment.
  - [2] Completely pull out the cartridge lever to unlock, which is located at the front of the equipment.
  - [3] Take the reagent cartridge out of the box (and bag).
  - [4] Insert the reagent cartridge into the receptacle firmly.
  - [5] Push the cartridge lever back in to lock and check to see that it is returned into the equipment.
- \*1: If the reagent cartridge lifts up when the cartridge lever is pushed in, take out the reagent cartridge and insert it all over again.
- \*2: If the bottom of the horizontal line in the reagent cartridge's surface design is not lined up with the edge of the front cover on the equipment, insert the reagent cartridge over again.
- \*3: At the time of the reagent cartridge replacement, remove a used reagent cartridge after [2] process.

### NOTE

- Do not use the reagent for the use other than the Colormetry.
- Do not disassemble the reagent cartridge and dispose it as chemical waste in accordance with local regulations.
- Before installing a reagent cartridge, always check the manufacture date on the package. (The cartridge life is about 1 year from the date of manufacture, and should be used up within approximately 4 months after installation.)
- When installing a reagent cartridge, insert it slowly, keeping the end of the tube from hitting the body of the equipment.
- Make sure to push the cartridge lever back into the equipment, or the cartridge may come off and may cause water leak when water pressure is applied during operation.
- Never remove the tube from the end of the reagent cartridge. Do not touch it; otherwise, the reagent injection volume may be affected.

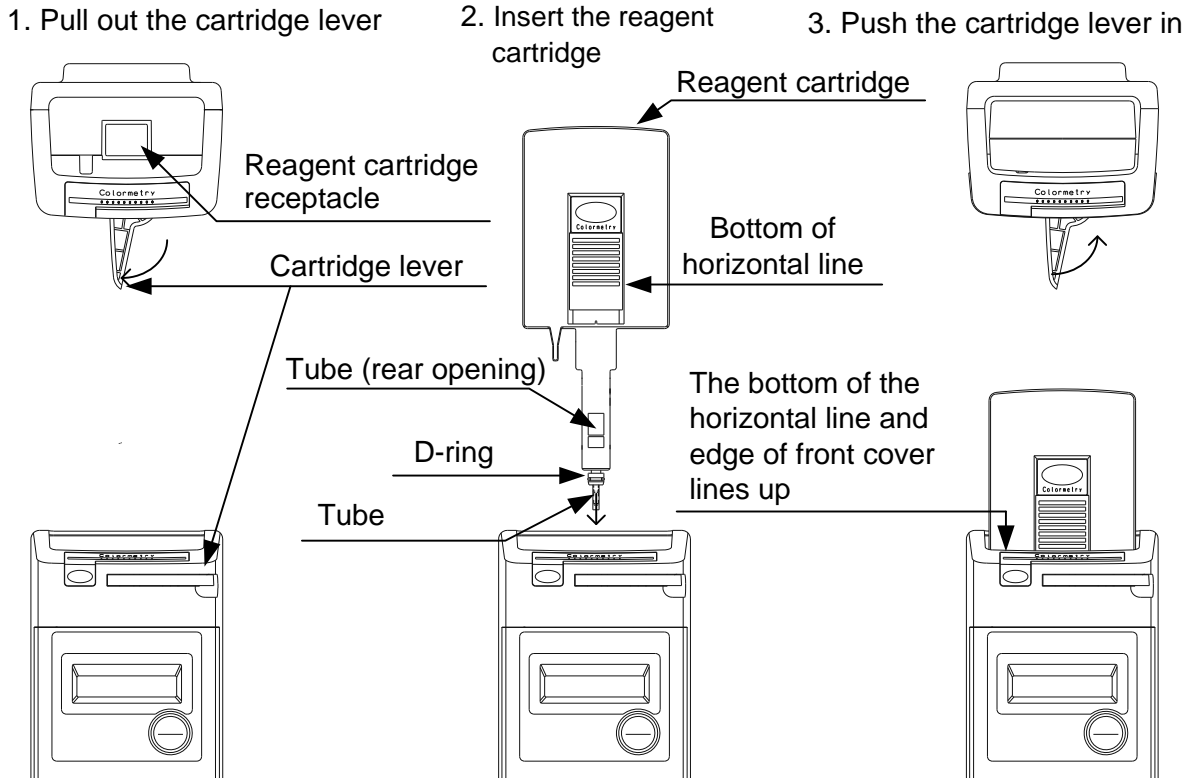

Fig.5-1

## 6 START UP

Check the following items before start up.

### 6.1 Checking the Installation

- [1] The Colormetry is designed for indoor installation only. Is it the installed free from rain and direct sunlight?
- [2] Is the operation environment appropriate (water pressure, water temperature and ambient temperature)?
- [3] Is the equipment firmly installed to a wall surface?
- [4] Is the reagent cartridge correctly installed and the cartridge lever firmly locked?
- [5] Is the filter assembly installed correctly?
  - (1) Is the fiber filter cartridge set in the filter casing assembly?
  - (2) Is the constant flow valve (a black rubber plate) installed at the top end of the filter casing assembly?
  - (3) Are the top and bottom filter cases of the filter casing assembly tightly assembled together?
  - (4) Is the filter casing assembly correctly mounted on the equipment?
- [6] Is there anything which should not get wet placed under the equipment?
- [7] Is the equipment free from excessive scratches or dirt?

### 6.2 Checking the Wiring

- [1] The equipment is specified at DC24V. Is the power supplied correctly (voltage, capacity and wire diameter)?
- [2] Is the earth leakage circuit breaker with overcurrent protection installed in the power supply line?
- [3] Is the equipment grounding terminal connected?
- [4] Are the wiring connections correct?
- [5] Is the wiring provided with a drooping slack and clamped firmly?
- [6] Have the terminals been retightened to be sure?

### 6.3 Checking the Piping

- [1] Are the feed-water and drain-water tube connections correct?
- [2] Are the feed-water and drain-water tubes free of bents and folds?
- [3] Is the drain-water tube open into the air and independent?
- [4] When the water pressure is applied, is there any leakage in the connecting parts?

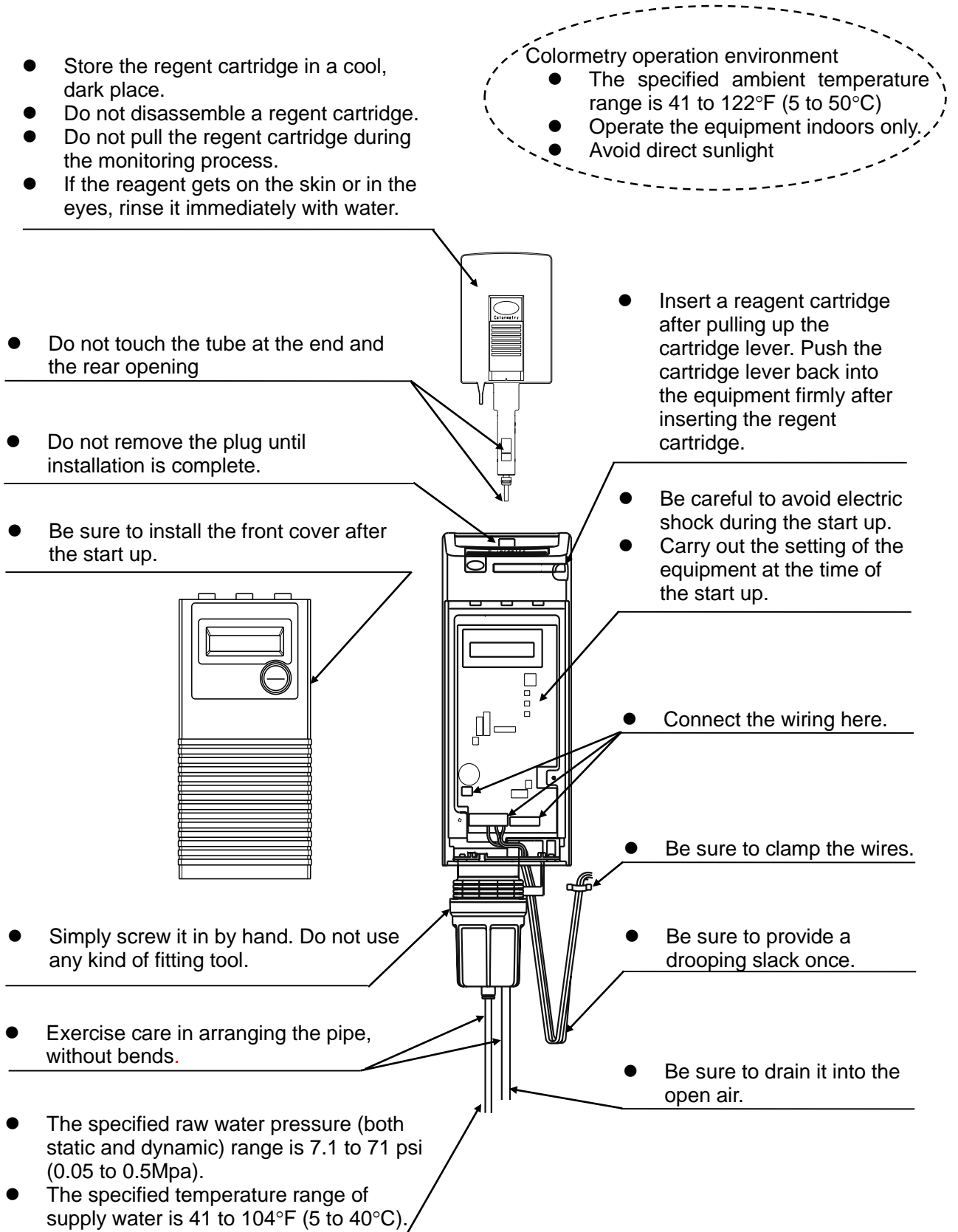

Fig.6-1

## 6.4 Setting Before Supplying the Power

The items described below must be set in order for the equipment to operate properly. The equipment can be operated as set at the factory. However, changing the settings are possible as required for each installation.

### Setting the DIP switch

Before supplying to the power, take off the front cover in the equipment and check the DIP switch setting. Change the setting if required. (See Fig.6-2)



(※) SW1-1: DSW1-1  
SW4-1: DSW4-1

#### [1] General settings

DSW1-3	DSW1-4	DSW4-1	DSW4-2	DSW4-3
OFF	OFF	ON	OFF	OFF

DSW1-3, DSW1-4, DSW4-1, DSW4-2 and DSW-4-3 need no changes, as they have been set at the factory. Simply verify the settings shown in the table above.

Set the DIP switch DSW4-2 to ON, the display change to simple English.

\*To cut the buzzer for a hardness leakage, system error and replacement of the regeneration cartridge all together from the beginning, set the DSW1-4 to ON

#### [2] Setting for M-alkaline value

DSW1-1	DSW1-2	M-alkaline value	Remarks
OFF	OFF	Under 60 mg/L	Factory setting
OFF	ON	Over 60 mg/L and under 120mg/L	
ON	OFF	Over 120 mg/L and under 300mg/L	
ON	ON	Over 300 mg/L and under 500mg/L	

### CAUTION



Change the DSW1-1 and DSW1-2 settings according to the M-alkaline value of the sample water.

Evaluation error may occur from a setting that is incompatible with the M-alkaline value of the sample water.

#### [3] Setting for online communication

Set the DSW1-5 to ON when using online communication. Set the DSW1-5 to OFF when there is no communication.

[4] Other DIP switches

DSW1-6, DSW1-7, DSW1-8 can be used to reset the Colormetry.

(1) All Clear (Reset all setting and data-memory and return to the initial state)

Erase all setting and data-memory and return to a factory setting condition.

Set the DSW1-6 ON, carry out the reset procedure (Set the DSW1-8 to OFF and change to ON, then to OFF).

(2) Memory Clear (Keep the setting data and reset all data-memory)

Retain the present setting, but erase all data-memory.

Set the DSW1-7 ON, carry out the reset procedure (Set the DSW1-8 to OFF and change to ON, then to OFF).

(3) Reset (Reset the microcomputer only)

Reset the microcomputer only.

Set the DSW1-6 and DSW1-7 to OFF, carry out the reset procedure (Set the DSW1-8 to OFF and change to ON, then to OFF).

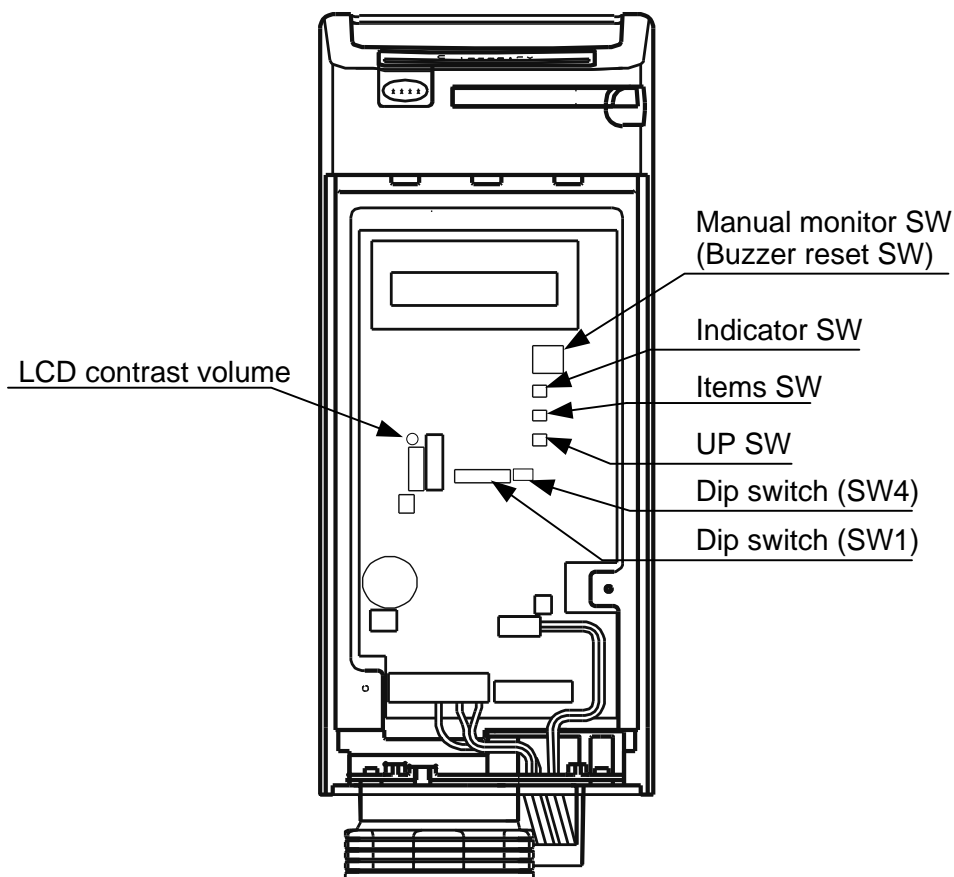

Fig.6-2



## 6.5 Power Supply

### NOTE

Be sure to check the following before supplying the power to equipment.

- [1] The power supply voltage is DC24V.
- [2] The wiring and piping are correct.
- [3] The reagent cartridge is properly installed.
- [4] Water pressure is applied and ready to feed sample water into the equipment.

### 6.5.1 Connect to power supply



## WARNING



Do not touch the power switch with wet hands.  
Failure to observe this precaution could result in an electric shock.

### NOTE

Supply the power to the equipment. Some units have the date-memory backup battery already charged, while others do not. Check and set the equipment accordingly.

- [1] When the data-memory backup battery has been charged by the time the power is supplied to the equipment or when restart the equipment after reset (Reset the microcomputer only).
  - (1) “CMU Ver...” message is displayed when the power supplied to equipment.
  - (2) Then, the display changes to “Hardness”.
  - (3) The equipment automatically enters to the self check mode to confirm the Colormetry works properly.
- [2] When the data-memory backup battery has not been charged when the power is supplied to the equipment or when restart the equipment after all clear(Reset all setting and data-memory and return to the initial state).
  - (1) “CMU Ver ...”is displayed when power is supplied to the equipment.
  - (2) Then, the display changes to “All Clear”.
  - (3) The mode automatically changes to Setting mode.  
Refer to section 6.6 setting mode on page 23 to set the items. Make sure to set the current date, time and the reagent cartridge replacement date.
  - (4) When all settings have been made, press the Indicator switch.
  - (5) “Hardness” is displayed.
  - (6) The equipment automatically enters to the self check mode to confirm the Colormetry works properly.
- [3] LCD adjustment  
If the LCD is hard to read, adjust it with the “LCD contrast volume”.

### NOTE

When the data-memory back up battery has been charged by the time the power supplied to the equipment, check the setting and change if it is required after the self check is completed. The setting procedure is show in section 6.6 Setting mode on page 23.

Flowchart of processes when the power supplied to the equipment

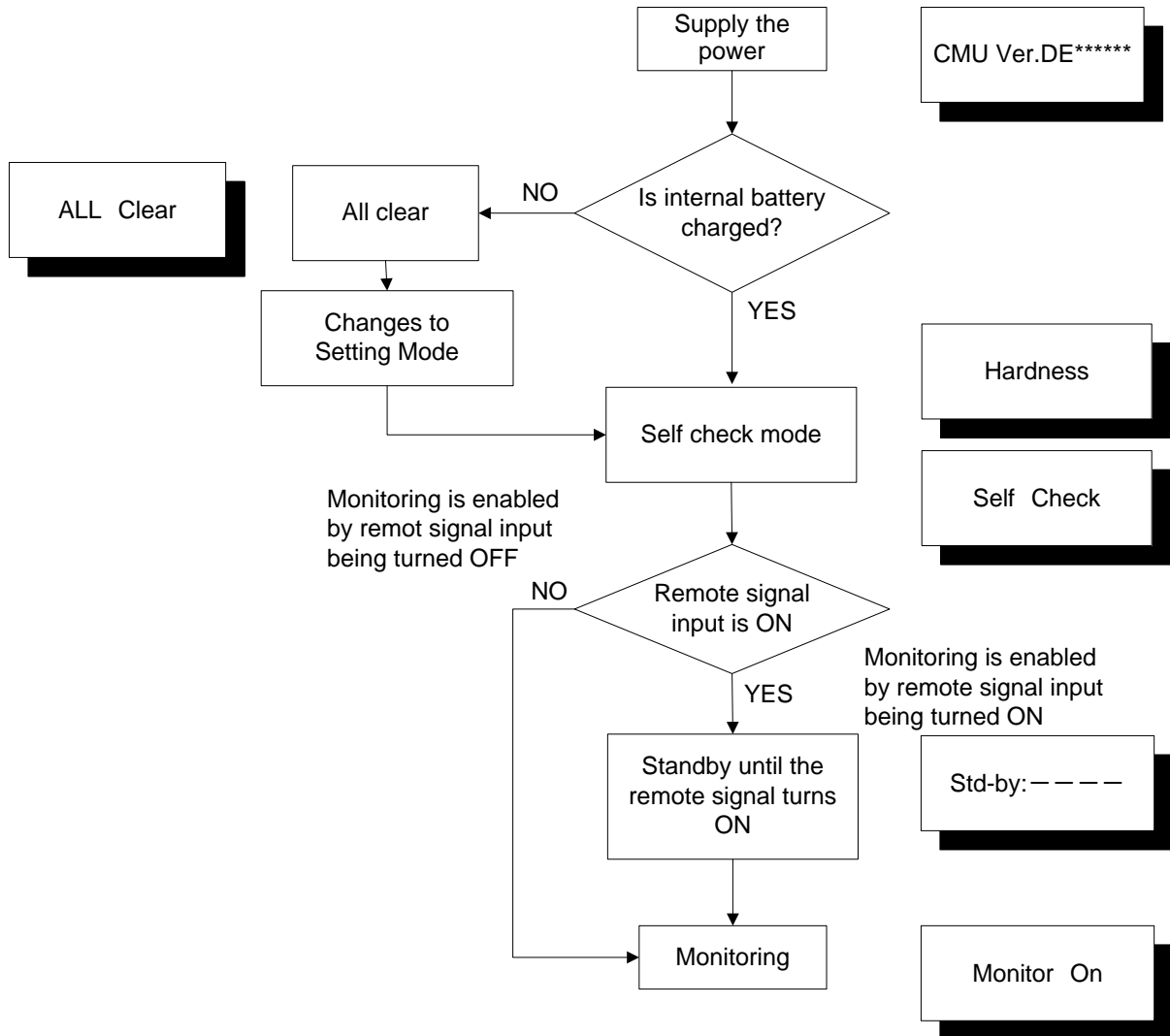

### 6.5.2 Self check mode

The equipment carries out the self check automatically to confirm that it is ready for operation.

- The automatic self check completes within two minutes if the equipment works properly and the buzzer sounds. And the mode changes to the monitoring mode automatically.

\* If the remote signal input is set as [S Rte Sgl ON], the equipment will stand by until the remote signal input turns ON.

- If the equipment is not normal condition, the self check is repeated.

The self check repeated up to 5 times automatically until the equipment checks out as normal, then the final result will be displayed. This process requires some times.

- During a repeated self check, "Self Check Retry" is displayed.
- If the equipment fails for the self check all 5 times, the buzzer sounds and the mode changes to the system error standby mode and an error message displays in the LCD.

#### **NOTE**

- "Wash F :F265" is displayed and buzzer sounds during start up or first operation after replacing the fiber filter in spite that the ball valve is open and pressure is applied, carry out the forced monitoring. This is an initial phenomenon caused by bubbles in the filter casing assembly. It is not a system error.
- Press the manual monitor switch to stop the buzzer, then press the manual monitor switch again for forced monitoring to feed water to the equipment. If the same alarm occurs, repeat this process several times.
- If the alarm occurs after repeating above process a couple of time, remove the constant flow valve (black rubber plate) from top of the filter casing assembly, and carry out the forced monitor in. If the alarm condition stopped, place the constant flow valve back to the filter casing assembly and perform forced monitoring to assure the alarm will not occur.

If the fiber filter is replaced while the power supplied, the equipment would not automatically enter the self check mode. Press the manual monitor switch to carry out forced monitoring. If the alarm occurs, repeat the forced monitoring as mentioned above.

## 6.6 Setting Mode

These items need to set up the Colormetry system for operation. Be sure to follow the procedure to set them, since they are important setting in monitoring operation and to know the replacement timing of the reagent cartridge.

How to enter and exit the setting mode

Each press of the Indicator switch changes the modes as follows.

See Fig.6-2 for the switch location.

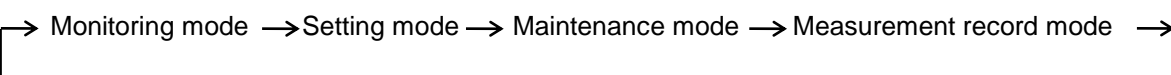

- To enter the setting mode: Press the indicator switch to the setting mode.
- To exit the setting mode: Press the indicator switch to exit from the setting mode.

The mode will automatically return to the monitoring mode if no switch is pressed for 10 minutes.

How to input setting item

[1] In the setting mode, press the item switch until the item to be set displayed.

[2] Press the up switch to vary the setting value.

(To vary a setting over a wide range, hold the up switch for over a second to start varying the value at a faster rate.)

[3] To make the changed value valid, press the item or indicator switches to change the item to set or mode.

Item	Sample indication	Setting range	Setting increment	Factory setting	Remark
Current date	S Date 10/23/06	00/01/01 ~ 50/12/31	1	-	*1
Current time	S Time 15:28	00:00 ~ 23:59	1	-	*1
Monitor interval	S Intvl 060min	030 ~ 240 min	30 min	060 min	*2
Monitor start time	S Start 08:30	00:00 ~ 23:59, 24:--		24:--	*3
Monitor stop time	S Stop 20:30	00:00 ~ 23:59	1	-	*3
Remote signal function	S Rte Sgl OFF	ON/OFF	-	OFF	*4
Remote signal delay	S DelayTime 10s	0 ~ 99 sec	1	0 sec	*5
Alarm set point	S AlarmSet 2mg/L	1, 2, 3, 5 mg/L	-	2 mg/L	*6
Abnormal condition	S Alarm Inc No:2	1 ~ 3 time	1	2 times	*7
Response cycle	S Alarm Det No:2	1 ~ 8 time	1	2 times	*8
Remote alarm output form	S Rte Alarm :NC	NC/NO	-	NC	*9
Reagent cartridge installation date	S C Rpl 10/23/06	00/01/01 ~ 50/12/31	1	-	*10
Remote signal ID	S Rte ID :00	-	-	00	*11
Communication ID	S Comm ID :00	-	-	00	*12

\*1: Current date and time

Set the current date and time.

\*2: Monitor interval

This is to set the interval between monitoring. It is originally set at 60 minutes at the factory. No change is required except for special circumstances. Be aware that if a 0 minutes is set, monitoring will be performed continuously.

**NOTE**

Be aware that if a 000 minutes is set, monitoring will be performed continuously.

It made the life span of the equipment will be shorten, the setting on or more than 60 minutes is recommended.

\*3: Monitor start and stop times

The monitor start and stop times settings limit the period during which monitoring is performed. The factory settings are for continuous 24-hour monitoring, "24:--". Even though change the item, will not display the stop time, which is not applicable to continuous 24-hour monitoring setting. Set the start and stop times according to the requirements at the site.

To set continuous 24-hour monitoring, enter "24:--" in the start time, or enter the same specific time in both the start and stop time.

\*4: Remote signal functions

The Colormetry may be started monitoring or keep in standby an external remote signal input. Set according to the requirements at the site.

[1] Rte Sgl OFF (factory setting)

Under this setting, scheduled monitoring is performed if the remote signal is being turned OFF when the monitor interval passed. For example, when the Colormetry is used for process water from the filtration equipment, the monitoring can be stopped while the filtration equipment is regenerating by using a remote regeneration signal from the filtration equipment.

[2] Rte Sgl ON

Monitoring starts if the remote signal is being turned ON when the monitor interval passed. For example, monitoring may be performed only while water is being fed, by using a feed-water control signal.

**NOTE**

[1] If no remote signal is connected, set to "S Rte Sgl OFF"

[2] If a feed-water signal is available at the site, utilize the signal as the first priority, to prevent evaluation and system errors.

\*5: Remote signal delay time

This sets the number of seconds for the monitoring is to be delayed after receiving the remote signal. It is not a commonly used function, so set it if required at the site. The factory setting is zero sec.

\*6: Alarm set point

The system allows setting up a specific concentration at which to issue the abnormal condition alarm. The setting may be 1mg/L, 2mg/L, 3mg/L and 5mg/L. The factory setting is 2mg/L

**NOTE**

For boiler use, please select "1 or 2mg/L" or scale may form in the boiler.

\*7: Concentration anomaly retry

If an evaluation result is the alarm set point and up, for high concentration anomaly (\*6 above), monitoring is repeated the number of times set by this item to confirm the result.

Likewise, if an evaluation result is lower than the alarm set point for low concentration anomaly (\*6 above), monitoring is repeated the number of times set by this item to confirm the result.

[1] If all repeated monitoring results are higher than the alarm set point for high concentration anomaly, the high concentration anomaly is determined. Also, if all repeated monitoring results are lower than the alarm set point for low concentration anomaly, the low concentration anomaly is determined.

(The actual concentration anomaly alarm is issued only if the condition set in the response alarm cycle is also satisfied. (\*8 below))

[2] If after repeated monitoring, the result is become below the alarm set point for high or low concentration anomaly, the result is determined as normal and the monitoring is finished.

\*8: Response alarm cycle

In addition, such an anomaly (\*7 above) must be repeated in a series of monitoring at a preset interval for a number of times. This item is set the number of times. When all of these monitoring results indicate a concentration anomaly, it is finally evaluated that a concentration anomaly exists and the alarm is issued.

\*9: Remote alarm output

Set the contact of the remote alarm. Factory setting is NC

Setting = "NC": When the alarm is issued, the remote alarm output turns OFF.

Setting = "NO": When the alarm is issued, the remote alarm output turns ON.

\*10: Reagent cartridge replacement date

The item updates the installation date of the reagent cartridge. Each press of the up switch alternatively indicates the reagent cartridge installation date or the current date. Normally, install (replace) the reagent cartridge while the power supplied will automatically update the installation date, so there is no need to set this item.

If the reagent cartridge is installed without the power supplied, such as during start up, it will not automatically update the installation date even though the power supplied afterward. If the installation date must be updated, press the up switch to update it.

**NOTE**

Note that if the up switch is used to switch the display from the installation date to the current date, then it can confirm the update by pressing either the Item or Indicator switch. Once it is update, it cannot set back to the previous date.

\*11: Remote signal ID

Remote signal ID and Communication ID are used for MIURA dedicated network only.

Please input "00"

\*12: Communication ID

Set a communication ID when using online communication or Miura Intelligence Flexibility System through DS-NET. Input "00" when there is no communication.

## 6.7 Monitor Operation

Verify whether monitoring is being performed properly after the items have been set.

### Checking the monitor operation (1)

“Monitor ON” is displayed during monitoring, regardless of whether it is on automatic or manual. When the monitoring is complete, “Result: \*\*\*\*” is displayed.

First, check that the pressure is applied and water is supplied. Press the manual monitor switch to start monitoring and see it complete properly.

If an error occurs during the monitoring process, the mode changes to the system error standby mode.

### Checking the monitor operation (2)

Verify that monitoring is being performed properly at the monitor interval and controlled correctly by the remote signal. Following procedure:

[1] Make sure that the pressure is applied and ready to feed water.

[2] Set the monitor interval at 000 min. in the setting mode.

It allows the equipment the continuous monitoring between the monitor start and stop times.

Set the monitor start and stop times as desired.

[3] If the remote signal input is not connected, check to see that the equipment performs monitoring continuously between the monitor start and stop times.

If a remote signal input is connected, check to see that the equipment performs monitoring or keeps in standby according to the remote signal being turned ON or OFF during the period between monitors start and stop times.

[4] After checking monitor operation, reset the monitor interval and monitor start and stop times to their original settings.



## 6.8 Alarm Setting

Check the alarm operation both a buzzer and remote alarm output according to below procedure.

- [1] Set the remote alarm output to "NO".  
Refer to "Setting mode" on page 23.
- [2] Set the DSW1-3 to ON.  
Refer to Section 6.4 "Setting before connecting power supply" on page 18.
- [3] Verify that "Thmsta F : C131" is displayed in the LCD, the buzzer sounds and the remote alarm contact closes.
- [4] Set the DSW1-3 to OFF, and restore the remote alarm output to their original setting.
- [5] Even though this is for the system checking purpose, the system error will be recorded.  
This record can be deleted through the memory clear procedure.  
Refer to Section 6.4 "Setting before connecting power supply" on page 18.

This image shows a blank sheet of white paper with a black border. The page is filled with horizontal dashed lines, spaced evenly from top to bottom, providing a guide for handwriting. There are 25 dashed lines in total, creating 24 rows for writing. The lines are consistent in length and spacing throughout the page.



---

AUTHORIZED REPRESENTATIVE in EU

Wolfgang Kiebert

Industrie- und Verfahrenstechnik

Dipl.-Ing. Wolfgang Kiebert

Kapellenstr. 19

D-54597 Auw bei Prüm

Tel. : +49 (0)6552 92 99 000

Fax : +49 (0)6552 92 99 004

Mobil : +49 (0)172 42 22 416

email : [ask@kiebert.de](mailto:ask@kiebert.de)

GERMANY, Mar 2017